

Bowei distribution network construction fee reduced

Test certification
CE  FC 



Overview

In Q1 2025, Bowei Logistics reported a staggering 37% reduction in last-mile delivery costs – but how did they achieve this through distribution network optimization?

Let's unpack their operational blueprint that's redefining supply chain management across Asia-Pacific markets. Many companies still. Air blast circuit breaker refurbishment is generally more cost effective than. At our Spares & Cable facility, we store, manage and distribute emergency strategic stock using UK wide fast delivery. approved demolition amount in the disposal plan. Facility costs decrease as the number of facilities is reduced as shown in Figure 4.

Bowei distribution network construction fee reduced



Bowei Distribution Network: Revolutionizing Global Supply Chains with

As we approach peak shipping season, companies using Bowei's distribution network report 30% fewer supply chain disruptions compared to industry averages. Now that's what we call a logistics force ...

Bowei distribution network demolition project fee

Although a circular economy for construction and demolition waste management has been promoted by the government in recent years, the transition from open-ended to close-looped circularity for ...



Bowei Distribution Network Engineering Cost Tutorial

This paper proposes a method to address several issues in the distribution system of distribution network materials, including non-transparent distribution costs, low punctuality of distribution,

PROJECT SPOTLIGHT THE GAME CHANGERS

Although a circular economy for construction and demolition waste management has been promoted by the government in recent years, the transition from open-ended to close-looped circularity for ...



Bowei Distribution Network Usage: Optimizing Supply Chain ...

In Q1 2025, Bowei Logistics reported a staggering 37% reduction in last-mile delivery costs - but how did they achieve this through distribution network optimization?

CASE STUDY RURAL CONNECTIVITY PROJECT

Although a circular economy for construction and demolition waste management has been promoted by the government in recent years, the transition from open-ended to close-looped circularity for ...



Bowei 20kv and below distribution network project

When you're looking for the latest and most efficient Bowei 20kv and below distribution network project for your PV

project, our website offers a comprehensive selection of cutting-edge products designed ...



Bowei distribution network demolition project fee

The construction and demolition waste disposal industry plays a vital role in improving the utilisation rate of construction and demolition waste worldwide, however, too



114KWh ESS



Bowei distribution network cost management system

What is a Distribution Network? A distribution network is a critical part of supply chain management that helps to ensure products are delivered efficiently from manufacturers

Bowei Distribution Network Engineering Design Manual

This manual provides the standard approach to underground distribution design for the Evoenergy distribution network. If the standard design

guidelines are not suitable for any particular

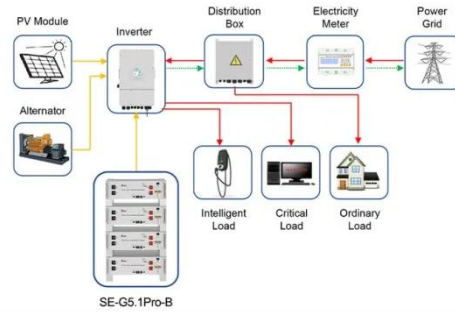

Application scenarios of energy storage battery products

Contact Us

For catalog requests, pricing, or partnerships, please visit:
<https://www.scelto.co.za>

